

TM 32-5865-010-24&P

TECHNICAL MANUAL

**MAINTENANCE INSTRUCTIONS
ORGANIZATIONAL, DIRECT SUPPORT, AND GENERAL SUPPORT
(INCLUDING DEPOT MAINTENANCE REPAIR PARTS
AND SPECIAL TOOLS LIST)**

**DIRECTION FINDER CONTROL-INDICATOR
C-10144/ALQ-151
NSN 5865-01-070-8961**

Tracer Aerospace Austin, Inc.
D A A K 2 1 - 8 4 - C - 0 0 9 9

**This publication is not available through AG Publications Center.
Requisition through Commander, US Army Electronics Materiel
Readiness Activity, Vint Hill Farms Station, Warrenton, Virginia
22186-5141.**

This TM supersedes TM 32-5865-010-24&P dated December 1984,

HEADQUARTERS, DEPARTMENT OF THE ARMY

MAY 1989

WARNING

High voltage is used in the operation of this equipment. Avoid contacting high-voltage connections when installing or repairing this equipment. Injury or death may result if personnel fail to observe safety precautions.

WARNING

Adequate ventilation should be provided while using trichlorotrifluoroethane. Prolonged breathing of vapor should be avoided. The solvent should not be used near heat or open flame; the products of decomposition are toxic and irritating. Since trichlorotrifluoroethane dissolves natural oils, prolonged contact with skin should be avoided. When necessary, use gloves that the solvent cannot penetrate. If the solvent is taken internally, consult a physician immediately.

SAFETY SUMMARY

The following are general precautions that are not related to any specific procedures and, therefore, do not appear elsewhere in this publication. These are recommended precautions that personnel must understand and apply during many phases of operation and maintenance.

KEEP AWAY FROM LIVE CIRCUITS

Operating personnel must at all times observe all safety regulations. Do not replace components or make adjustments inside the equipment with the high-voltage supply turned on. Under certain conditions, dangerous potentials may exist when the power control is in the off position, due to charges retained by capacitors. To avoid casualties, always remove power and discharge and ground a circuit before touching it.

DO NOT SERVICE OR ADJUST ALONE

Under no circumstances should any person reach into or enter the enclosure for the purpose of servicing or adjusting the equipment except in the presence of someone who is capable of rendering aid.

WARNINGS AND CAUTIONS

The following warnings and cautions are used in the text of this volume and are repeated here for emphasis:

WARNING

High voltage is used in the operation of this equipment. Avoid contacting high-voltage connections when installing or repairing this equipment. Injury or death may result if personnel fail to observe safety precautions.

WARNING

Adequate ventilation should be provided while using trichlorotrifluoroethane. Prolonged breathing of vapor should be avoided. The solvent should not be used near heat or open flame; the products of decomposition are toxic and irritating. Since trichlorotrifluoroethane dissolves natural oils, prolonged contact with skin should be avoided. When necessary, use gloves that the solvent cannot penetrate. If the solvent is taken internally, consult a physician immediately.

Technical Manual

No. 32-5865-010-24&P

HEADQUARTERS
DEPARTMENT OF THE ARMY
WASHINGTON,DC, 15 MAY 1989

ORGANIZATIONAL, DIRECT SUPPORT, AND GENERAL SUPPORT
MAINTENANCE MANUAL
INCLUDING DEPOT MAINTENANCE REPAIR
AND SPECIAL TOOLS LIST
FOR
DF CONTROL INDICATOR C-10144/ALQ-151
5865-01-070-8961

REPORTING OF ERRORS

You can improve this manual by recommending improvements using DA Form 2028-2 located in the back of the manual. Simply tear out the self-addressed form, fill it out as shown on the sample, fold it where shown, and drop it in the mail.

If there are no blank DA Forms 2028-2 in the back of your manual, use the standard DA Form 2028 (Recommended Changes Publications and Blank Forms) and forward to the Commander, U.S. Army Electronic Materiel Readiness Activity, Vint Hill Farms Station ATTN: SELEM-ME-E Warrenton, Virginia 22186.

In either case, a reply will be furnished directly to you.

	Paragraph	Page
CHAPTER 1.	INTRODUCTION	
Section I.	GENERAL	
	Scope	1-1 1-1
	Maintenance Forms and Records	1-2 1-1
	Destruction of Army Materiel to Prevent Enemy Use...	1-3 1-1
	Administrative Storage	1-4 1-1
	Calibration	1-5 1-1
	Reporting of Errors	1-6 1-1
	Reporting Equipment Improvement Recommendations	1-7 1-2
II.	DESCRIPTION AND DATA	
	Description	1-8 1-2
	Tabulated Data	1-9 1-2
CHAPTER 2.	ORGANIZATIONAL SUPPORT MAINTENANCE INSTRUCTIONS	
CHAPTER 3.	FUNCTIONING OF EQUIPMENT	
Section I.	GENERAL	
	Scope	3-1 3-1
II.	FUNCTIONAL DESCRIPTION	
	Overall Functional Description	3-2 3-1
CHAPTER 4.	DIRECT SUPPORT MAINTENANCE INSTRUCTIONS	
Section I.	GENERAL	
	Scope	4-1 4-1
CHAPTER 5.	GENERAL SUPPORT MAINTENANCE INSTRUCTIONS	
Section I.	GENERAL	
	Introduction	5-1 5-1
II.	TOOLS AND TEST EQUIPMENT	
	Standard Tools and Test Equipment	5-2 5-1
	Special Test Equipment	5-3 5-1
III.	TROUBLESHOOTING	
	General	5-4 5-2
	Test Setup Procedures	5-5 5-2
	Troubleshooting Procedures	5-6 5-2
IV.	MAINTENANCE	
	General	5-7 5-6
	Inspection	5-8 5-6
	Cleaning	5-9 5-6
	Removal and Replacement	5-10 5-7
	Repair	5-11 5-10
V.	GENERAL SUPPORT TESTING PROCEDURES	
	Introduction	5-12 5-12
	Performance Test	5-13 5-13
APPENDIX A.	REFERENCES	
	Technical Manuals	A-1 A-1
	Technical Bulletins	A-2 A-2
	Supply Bulletins	A-3 A-2
	Common Table of Allowances	A-4 A-2
	Army Regulations	A-5 A-2
	Forms	A-6 A-3
B.	MAINTENANCE ALLOCATION CHART	
Section I.	INTRODUCTION	
	General	B-1 B-1

	Paragraph	Page
Maintenance Functions	B-2	B-1
Column Entries Used in the MAC	B-3	B-2
Column Entries Used in Tool and Test Equipment Requirements (Section III)	B-4	B-3
Explanation of Columns in Section IV	B-5	B-4
II. MAINTENANCE ALLOCATION CHART		
III. TOOL AND TEST EQUIPMENT REQUIREMENTS		
APPENDIX C. REPAIR PARTS AND SPECIAL TOOLS LIST		
Section I. INTRODUCTION		
Scope	C-1	C-1
General	C-2	C-1
Explanation of Columns	C-3	C-1
Special Information	C-4	C-4
How to Locate Repair Parts	C-5	C-4
Abbreviations	C-6	C-4
II. Repair Parts List		
III. Special Tools List		
IV. NATIONAL STOCK NUMBER AND PART NUMBER INDEX		
APPENDIX D. EXPENDABLE SUPPLIES AND MATERIALS LIST		
Section I. INTRODUCTION		
Scope	D-1	D-1
Explanation of Columns	D-2	D-1
II. EXPENDABLE SUPPLIES AND MATERIALS LIST		
INDEX		Index-1

LIST OF ILLUSTRATIONS

Figure		Page
1-1	DF Control-Indicator C-10144/ALQ-151	1-3
5-1	DF Control-Indicator Test Setup Diagram	5-3
5-2	DF Control-Indicator Component Location Diagram	5-8
5-3	Switch/Indicator Assembly	5-11
C-1	Direction Finder Control Indicator C-10144/ALQ151	C-6
FO-1	DF Control-Indicator Schematic Diagram	

LIST OF TABLES

Table		Page
1-1	DF Control/Indicator Physical and Electrical Characteristics	1-2
5-1	Tools and Test Equipment for General Support Maintenance	5-1
5-2	DF Control/Indicator Troubleshooting Procedures	5-4

CHAPTER 1

INTRODUCTION

Section I. GENERAL

1-1. Scope.

This manual provides organizational, direct support and general support maintenance instructions and the repair parts and special tools list (RPSTL) for the Direction Finder Control-Indicator C-10144/ALQ-151, hereinafter referred to as the DF control-indicator. Included are unit description and data, instructions for corrective maintenance and theory of operation.

1-2. Maintenance Forms and Records.

Department of the Army forms and procedures used for equipment maintenance will be those prescribed by DA PAM 738-750, The Army Maintenance Management System (TAMMS).

1-3. Destruction of Army Materiel to Prevent Enemy Use.

General Procedures for the destruction of Army materiel are contained in TM 750-244-2, Procedures for Destruction of Electronics Materiel to Prevent Enemy Use (Electronics Command).

1-4. Administrative Storage.

For test procedures, forms and records, and inspection required during administrative storage of this equipment, refer to TM 740-90-1, Administrative Storage of Equipment.

1-5. Calibration.

There are no calibration requirements for this equipment.

1-6. Reporting of Errors.

The reporting of errors, omissions, and recommendations for improving this publication by the individual user is encouraged. Reports should be submitted on DA Form 2028 (Recommended Changes to Publications) and forwarded directly to the Commander, U.S. Army Electronics Materiel Readiness Activity, Vint Hill Farms Station, Warrenton, Virginia 22186, Attn: SELEM-ME-E.

1-7. Reporting Equipment Improvement Recommendations.

EIRs will be submitted on SF 368, Quality Deficiency Report, in accordance with DA PAM 738-750 (TAMMS). EIRs should be mailed directly to the Commander, U.S. Army Electronics Material Readiness Activity, Vint Hill Farms Station, Warrenton, Virginia 22186, Attn: SELEM-ME-E. A reply will be furnished directly to you.

Section II. DESCRIPTION AND DATA

1-8. Description.

The DF control-indicator (figure 1-1) is a rack mounted unit that houses eight momentary action, pushbutton switch/indicators. Each switch contains normally closed contacts and provides a momentary open condition when pressed. The indicator portion of the switch assembly is activated by a ground return from an external source. The unit requires 28 V dc with all input/output connections done via two rear panel connectors.

1-9. Tabulated Data.

Table 1-1 contains a list of physical and electrical characteristics of the DF control-indicator unit.

Table 1-1. DF Control-Indicator physical and Electrical Characteristics

Characteristic	Parameter
<u>Electrical</u>	
Input power (indicators)	+28 V dc
Switches	Normally closed
Indicators (illuminate)	External ground
<u>Physical</u>	
Height	4.5 in.
Width	4.87 in.
Depth (top)	5.85 in.
Depth (bottom)	6.61 in.
Weight	1.5 lb.

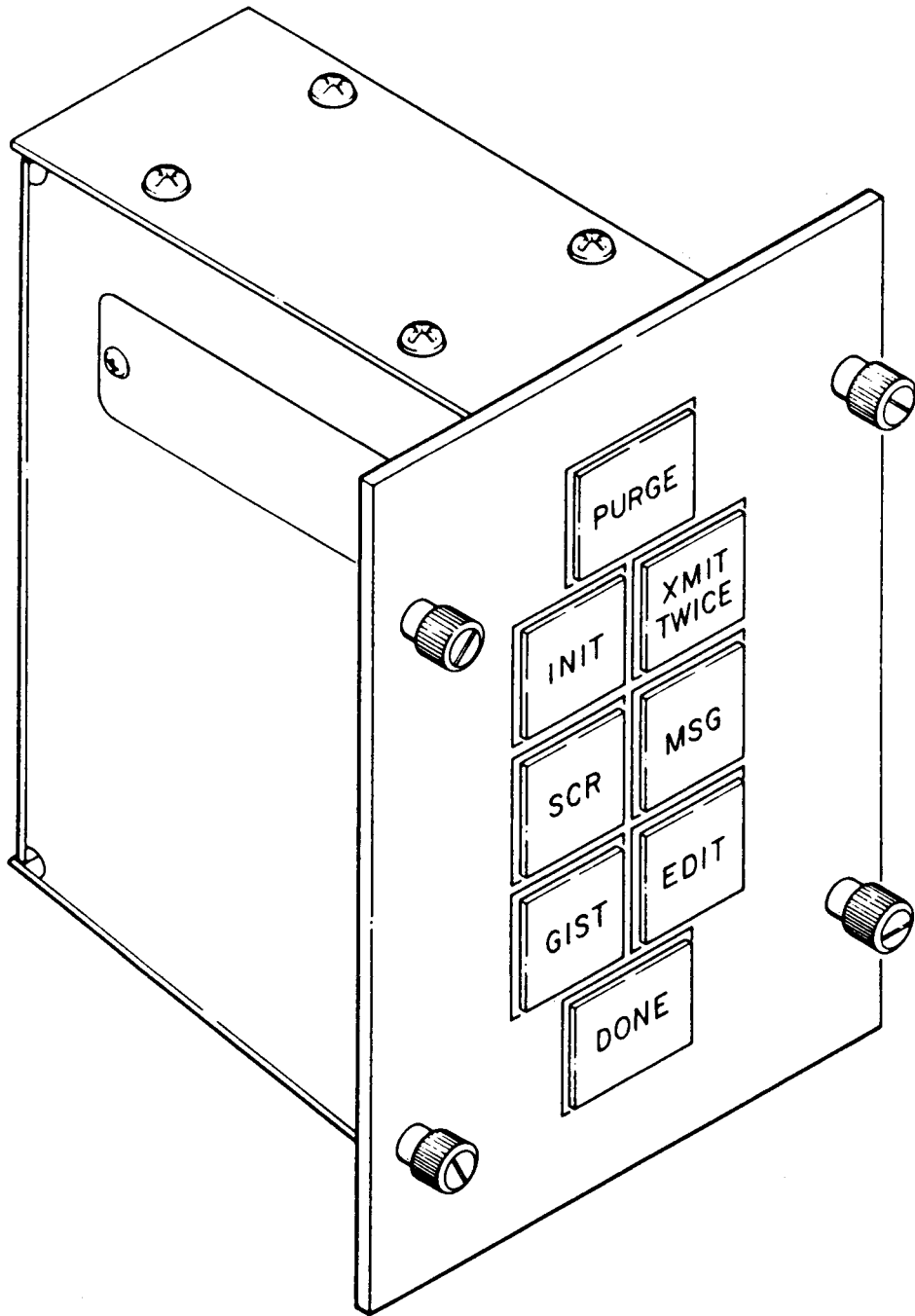

Figure 1-1. DF Control-Indicator C-10144/ALO-151

CHAPTER 2

ORGANIZATIONAL SUPPORT MAINTENANCE INSTRUCTIONS

2-1. Scope.

Organizational support maintenance instructions are contained in TM 32-5865-007-20&P and TM 32-5865-012-20/20P

CHAPTER 2

ORGANIZATIONAL SUPPORT MAINTENANCE INSTRUCTIONS

2-1. Scope.

Organizational support maintenance instructions are contained in TM 32-5865-007-20&P and TM 32-5865-012-20/20P

CHAPTER 3

FUNCTIONING OF EQUIPMENT

Section I. GENERAL

3-1. Scope.

This chapter contains theory of operation on the DF control-indicator. Due to simplicity of the unit, discussion will be limited to an overall functional description, followed by a description of two different types of switch/indicators used.

Section II. FUNCTIONAL DESCRIPTION

3-2. Overall Functional Description.

The DF control-indicator consists of eight switch/indicator assemblies, two connectors, and associated wiring. The switch/indicator assemblies are all momentary action, pushbutton, normally closed type switches. As shown in Figure FO-1, pressing switch/indicators S1 thru S7 creates an open between switch contacts 9 and 10. Releasing the switch establishes contact between these pins.

Pin 10 of switches S1 thru S4 are all connected to pin 53 of connector J1, which provides an external ground input when interconnected in a system configuration. Pressing switch S1 creates an open between J1-53 and J1-51. Pressing switch S2 creates an open between J1-53 and J1-50. Pressing switch S3 creates an open between J1-53 and J1-46, and pressing switch S4 creates an open between J1-53 and J1-47.

Pin 10 of switches S5, S6 and S7 are all connected to pin 54 of connector J11 which also provides an external ground input when interconnected in a system configuration. Pressing switch S5 creates an open between J1-54 and J1-52; pressing switch S6 creates an open between J1-54 and J1-48; and pressing switch S7 creates an open between J1-54 and J1-49.

Switch/indicator S8 differs from switch/indicators S1 thru S7, in that it has two sets of switch contacts. The first set of contacts, pins 9 and 10, is normally closed when the switch is released, and provides continuity between J2-B and J2-C. The second set of contacts, pins 9 and 11, is closed when the switch is pressed, and provides continuity between J2-B and J2-D. As shown in figure FO-1, a third set of contacts, pins 5 and 6, is also present on the switch, but is not used in this application.

The indicator portion of switch/indicators S1 thru S8 accepts +28 V dc power on pin C. These pins are all connected to pin 42 of connector J1, which is the +28 V dc power input pin for the unit. A ground potential applied to switch/indicator contacts 1 and 4 will illuminate the indicator portion. A ground potential applied to pin 30 of connector J1 will illuminate the indicator portion of switch/indicator S1. Similarly, a ground potential at J1-32, J1-36, J1-34, J1-38, J1-40, J1-44, and J2-E will illuminate the indicator portion of switch/indicators S2 thru S8, respectively.

CHAPTER 4

DIRECT SUPPORT MAINTENANCE INSTRUCTIONS

Section I. GENERAL

4-1. Scope . No direct support maintenance is required for this equipment. Units removed during organizational maintenance are forwarded to the general support level for maintenance as described in chapter 5.

CHAPTER 5

GENERAL SUPPORT MAINTENANCE INSTRUCTIONS

Section I. GENERAL

5-1. Scope.

This chapter contains general support maintenance instructions on the DF control-indicator. Maintenance instructions consist of testing, troubleshooting, disassembly, assembly and repair procedures, and are limited in scope to those procedures authorized in the maintenance allocation chart in appendix B. General support maintenance personnel, using tools and test equipment listed in section II, troubleshoot the unit in accordance with procedures detailed in section IV. The unit is then tested in accordance with performance test procedures in section V, to verify that the fault has been successfully found and repaired.

Section II. TOOLS AND TEST EQUIPMENT

5-2. Standard Tools and Test Equipment.

A list of tools and test equipment required to support the DF control-indicator at the general support level of maintenance. The table consists of an item number column, a nomenclature column, and an NSN or FSCM number column.

5-3. Special Test Equipment.

The OQ-337/ALQ-151 Test Set Group is required for the testing of the DF control-indicator at the general support level. No special tools are required.

Table 5-1. Tools and Test Equipment for General Support Maintenance

Item no.	Nomenclature	NSN or FSCM number
1	Maintenance Kit MK-1961/G	6625-01-068-1667
2	Digital Multimeter AN/PSM-45	6625-01-139-2512
3	Tool Kit TK-105/G	5180-00-610-8177
4	Tool Kit TK-100/G	5180-00-605-0079
5	Riveter Kit HP-200	6665-01-022-4165

Section III. TROUBLESHOOTING

5-4. General.

This section contains troubleshooting procedures for the DF control-indicator at general support level of maintenance. Also included are a test setup diagram (figure 5-1) and instructions required to prepare the unit for troubleshooting. Troubleshooting procedures contained in this section provided an aid in locating faults. To support troubleshooting, functional descriptions of the circuits in the unit are described in chapter 3. A schematic diagram is depicted in figure FO-1 and component location is provided in figure 5-2.

5-5. Test Setup Procedures.

To prepare the DF control-indicator for troubleshooting, refer to figure 5-1 and proceed as follows:

- a. Install the C10144 special test plug, PN TA0021, on connector J2 of the UUT.
- b. **Install** special test cable no. 1, PN TA0006, between the test **set and** the UUT.
- c. **Proceed** to paragraph 5-6 for troubleshooting procedures.

5-6. Troubleshooting Procedures.

Troubleshooting procedures for the DF control-indicator are presented in table 5-2. The table is divided into four columns: Step, Procedure, Normal Indication, and Repair Procedure. If an indication other than that listed in the Normal Indication column is present, follow the procedure delineated in the Repair Procedure column. Refer to paragraph 5-8 for detailed repair instructions. After a repair has been accomplished, perform the test procedure in section V of this chapter.

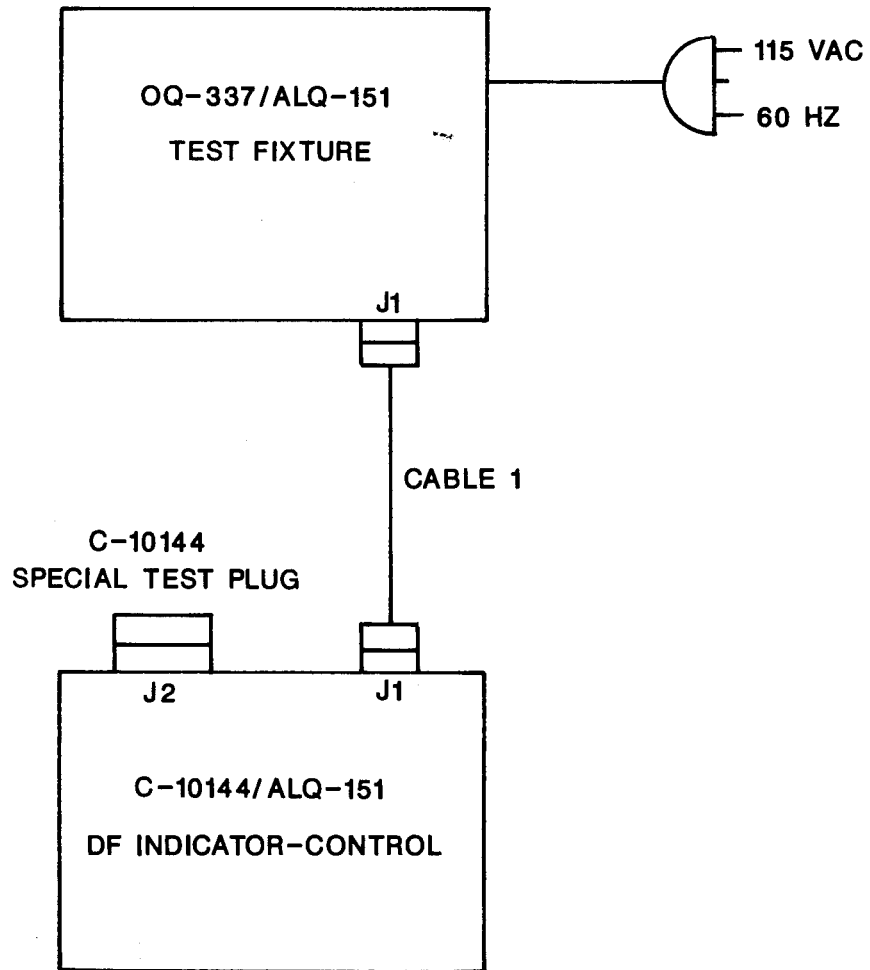

Figure 5-1. DF Control-Indicator Test Setup Diagram

Table 5-2. DF Control-Indicator Troubleshooting Procedures

Step	Procedure	Normal Indication	Repair Procedure
1	<p>a. Verify that test setup procedures in paragraph 5-5 have been accomplished.</p> <p>b. Verify that power switch S35 on test set is ON.</p> <p style="text-align: center;">NOTE</p> <p>After observing the normal indication in each of the following steps, release the switch-indicator and proceed to the next step.</p>	All switch/indicators are illuminated.	Replace defective bulbs in corresponding switch/indicator.
2	Depress and hold PURGE switch/indicator S1.	Indicator portion of S1 is extinguished.	Replace switch/indicator S1.
3	Depress and hold INIT switch/indicator S2.	Indicator portion of S2 is extinguished.	Replace switch/indicator S2.
4	Depress and hold SCR switch/indicator S3.	Indicator portion of S3 is extinguished.	Replace switch/indicator S3.
5	Depress and hold MSG switch/indicator S4.	Indicator portion of S4 is extinguished.	Replace switch/indicator S4.
6	Depress and hold GIST switch/indicator S5.	Indicator portion of S5 is extinguished.	Replace switch/indicator S5.
7	Depress and hold EDIT switch/indicator S6.	Indicator portion of S6 is extinguished.	Replace switch/indicator S6.
8	Depress and hold DONE switch/indicator S7.	Indicator portion of S7 is extinguished.	Replace switch/indicator S7.

Table 5-2. DF Control-Indicator Troubleshooting Procedures

Step	Procedure	Normal Indication	Repair Procedure
9	Depress and hold XMIT TWICE switch/indicator S8.	Indicator portion of S8 is extinguished.	Replace switch/indicator S8.
10	Disconnect the test plug and interconnect cable from the UUT.		
11	Set power switch S35 on test set to OFF. Set multimeter to measure ohms. Connect one lead to J2-D and one lead to J2-B.	Multimeter should read infinity.	Replace switch/indicator S8.
12	While keeping the multimeter connected as in step II, depress S8.	Multimeter should read continuity.	Replace switch/indicator S8.
13	Disconnect multimeter. End of procedures.		

Section IV. MAINTENANCE

5-7. General.

This section contains inspection, cleaning, removal, replacement, and repair procedures authorized by the maintenance allocation chart in appendix B for the general support maintenance level. Removal procedures are presented in a logical sequence to completely disassemble the unit. Disassemble the unit only to the extent necessary to perform a particular test or repair. Refer to figure 5-2 for component location. Once the unit is disassembled to the extent required, repair the unit in accordance with paragraph 5-11 and replace all assemblies previously removed. With the repaired unit completely assembled, verify proper operation by performing the tests in section V.

5-8. Inspection.

To inspect the DF control-indicator, remove the side panel in accordance with paragraph 5-10e, then proceed as follows:

- a. Inspect the exterior of the unit for dirt, corrosion, dents, scratches, and chipped paint.
- b. Check cable connectors for correct pin depths.
- c. Inspect the interior of the unit for dirt, corrosion, and foreign objects.
- d. Inspect the interior of the unit for burned, frayed, short-circuited, broken, or loose wires. Inspect for kinks and strained, cut, frayed, or otherwise damaged insulation.
- e. Inspect cable connectors for broken or shorted wires.
- f. Inspect connectors and chassis for loose or missing screws.

5-9. Cleaning.

To clean the DF control-indicator, proceed as follows:

- a. Remove dust and loose dirt from exterior surfaces with a clean, soft cloth (item 2, App. D).
- b. Remove dust and dirt from cable connectors, internal wiring, and other surfaces with a soft brush (item 1, App. D).

WARNING

Adequate ventilation should be provided while using trichlorotrifluoroethane. Prolonged breathing of vapor should be avoided. The solvent should not be used near heat or open flame; the products of decomposition are toxic and irritating. Since trichlorotrifluoroethane dissolves natural oils, prolonged contact with skin should be avoided. When necessary, use gloves (item 3, App. D) that the solvent cannot penetrate. If the solvent is taken internally, consult a physician immediately.

- (3) Remove grease and/or ground-in dirt with a cloth dampened (not wet) with trichlorotrifluoroethane (item 5, App. D).

5-10. Removal and Replacement.

a. Top and Bottom Cover Removal and Replacement. To remove top or bottom cover (1) (figure 5-2) of the unit, loosen the four fasteners (2) securing covers and remove covers. To replace covers, position the covers over the top or bottom of the unit and secure to the unit with the four fasteners.

b. Rear Panel Removal and Replacement. To remove the rear panels (3) from the unit, proceed as follows:

- (1) Remove six screws (4) and washers (5) that secure rear panel to unit.
- (2) Remove from each, four screws (8), flat washers (9), lockwashers (10) and nuts (11) that secure connectors ,J1 and J2 (6 and 7), then remove rear panel.
- (3) To replace rear panel (3), secure connectors J1 and J2 to panel with four screws (8), flat washers (9), lockwashers (10) and nuts (11), then secure rear panel to unit with six screws (4) and washers (5) .

NOTE

Two size sockets are utilized in connectors J1 and J2 of the DF Control Indicator. For number 20 sockets, use tool number MS27495A20 for insertion and MS27495R20 for socket removal. For number 22D sockets, use total number MS27495A22M for insertion of sockets and MS27495R22M for socket removal. These insertion/extraction tools are part of MK-1961/G tool kit.

c. Connector J1 and J2 Removal and Replacement. To remove connector J1 (6) and/or J2 (7) from the unit, proceed as follows:

- (1) Remove the rear panel as directed in paragraph 5-10b, step 1.
- (2) Remove connector J1 (6) and/or J2 (7) by removing four screws (8), washers (9), lock washers (10), and nuts (11) from the connector.
- (3) Tag and remove each wire from the connector using appropriate removal tool. Then remove the connector from the rear panel.

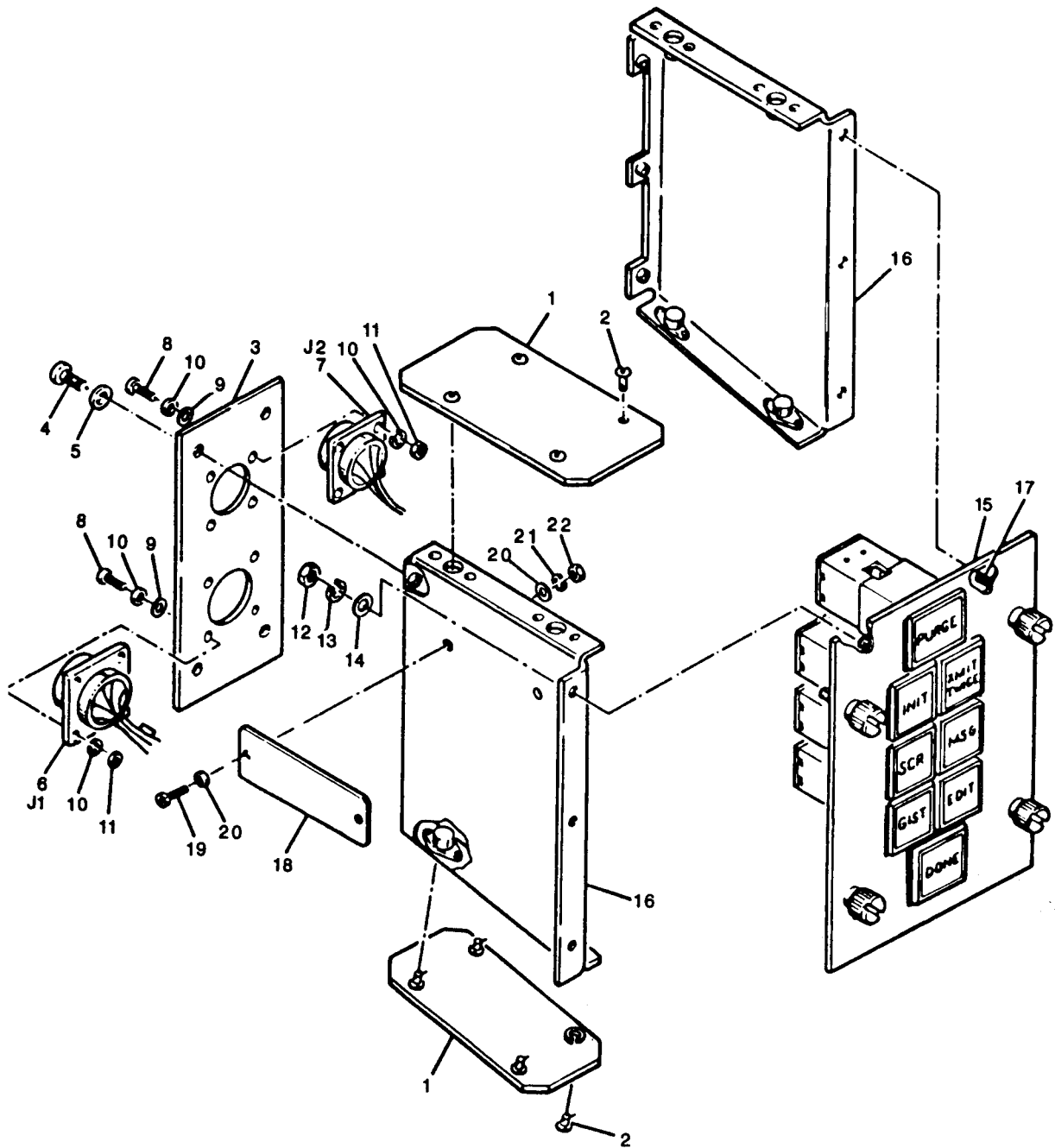

Figure 5-2. DF Control-Indicator Component Location Diagram

- (4) To replace either connector J1 or J2, insert wires into connector as tagged during removal using appropriate insertion tool.
- (5) Attach connector J1 (6) and/or J2 (7) to rear panel with four screws (8), washers (9), lock washers (10), and nuts (11).
- (6) Replace rear panel in accordance with paragraph 5-10b.

d. Front Panel Removal and Replacement. The front panel cannot be removed from the unit without removing all eight switch/indicators or their respective wiring. The front panel may be detached from the unit as follows:

- (1) Remove six nuts (12), lock washers (13), and flat washers (14) securing the front panel (15) to the side plates (16).
- (2) Remove eight switch/indicators in accordance with paragraph 5-11a, steps (2) through (5) .
- (3) Detach the front panel from the unit.
- (4) To replace front panel, replace eight switch/indicators in accordance with paragraph 5-11a, steps (6) through (10).
- (5) Aline the six clinch studs (17) on front panel with six mounting holes on the side plates (16) , and secure with six flat washers (14), six lock washers (13) and nuts (12).

e. Left and Right Side Panel Removal and Replacement. To remove left or right side panel (16) from the unit, proceed as follows:

- (1) Remove top and bottom covers (1) in accordance with paragraph 5-10a.
- (2) Remove three screws and washers (4 and 5) that secure rear panel (3) to side panel.
- (3) Remove three nuts (12), lock washers (13) and flat washers (14) that secure side panel to front panel (15).
- (4) When removing the right side panel (16), remove identification plate (18) by removing two screws (19), four flat washers (20), two lock washers (21) and nuts (22) that secure the plate to the side panel.
- (5) To replace side panel, aline three clinch studs (17) on front panel through mounting holes on side panel and secure with three flat washers (14) , lock washers (13) and nuts (12). When replacing right side panel (16) , secure identification plate (18) to panel with two screws (19), four flat washers (20), two lock washers (21) and nuts (22).

- (6) Replace top and bottom covers (1) in accordance with paragraph 5-10a.

f. Identification Plate Removal and Replacement. To remove identification plate (22) from side panel, proceed as follows:

- (1) Remove top access cover (1) in accordance with paragraph 5-10a.
- (2) Remove identification plate by removing two screws (23), four flat washers (20), two lock washers (25), and nuts (24) securing plate to side panel (21) .
- (3) Attach replacement identification plate (22) to side panel (21) by alining mounting on plate with those on side panel and securing with two screws (23), four flat washers (20), two lock washers (25), and nuts (24).
- (4) Replace top access cover in accordance with paragraph 5-10a.

5-11. Repair.

Repair instructions for the DF control-indicator consist of replacing defective switch/indicators, and performing rivet and fastener repair.

a. Switch/Indicator Removal and Replacement. To replace a switch/indicator, proceed as follows:

- (1) Remove front panel as required to gain access to the rear of defective switch/indicator. Refer to paragraph 5-10d.
- (2) To remove the indicator portion of the switch/indicator (figure 5-3), grasp the edges and pull straight out.

NOTE

The switch/indicator assemblies are equipped with a retaining strap that allows the indicator portion to hang free from the switch assembly without becoming separated.

- (3) Using a screwdriver, loosen the two locking cam adjustment screws until the two locking cams are free.
- (4) Slide the switch assembly forward to gain access to the switch wiring.
- (5) Using contact removal tool MS-27534-20 (MK-1961/G) , remove and tag each wire from the defective switch and remove switch assembly with associated mounting and retaining sleeves.

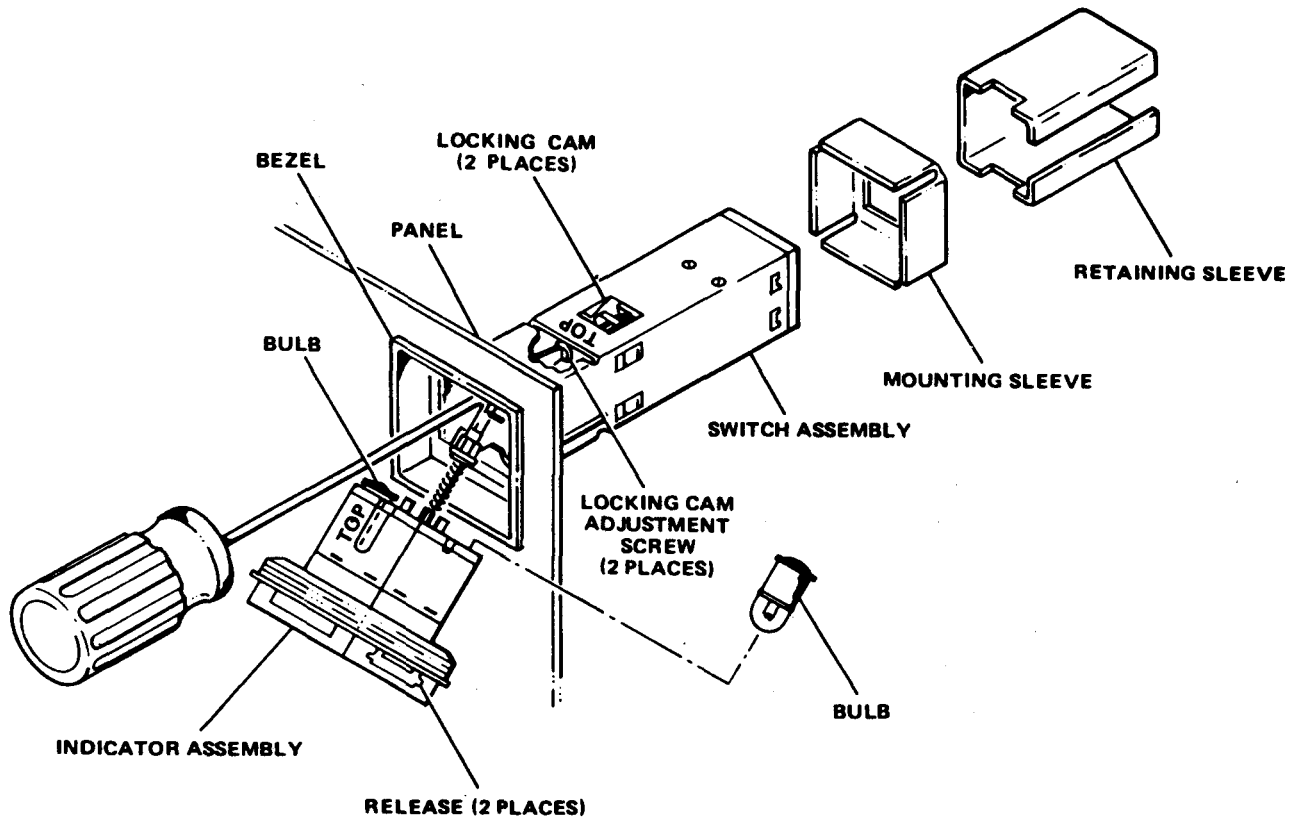

Figure 5-3. Switch/Indicator Assembly

- (6) Using a screwdriver, loosen the two locking cam adjustment screws on the replacement switch until two locking cams are free.
- (7) Remove the mounting and retaining sleeve from replacement switch assembly.
- (8) Slide the replacement switch assembly into the front panel, and replace the mounting and retaining sleeves on switch assembly from the rear of the front panel.
- (9) Using contact insertion tool MS-27534-20 (MK-1961/G), insert each wiring pin into corresponding terminals on the replacement switch assembly.
- (10) Slide the mounting sleeve up to the rear of front panel, and slide the retaining sleeve against the mounting sleeve.
- (11) Using a screwdriver, tighten two locking cam adjustment screws.
- (12) Install two bulbs in the indicator portion of the assembly.
- (13) Verify the TOP label on the indicator portion is facing up; align the indicator portion with the switch portion and push in, to the mechanical stop.

(14) Replace front panel in accordance with paragraph 5-10d.

5-11b. Riveting. To replace a rivet(s) on the unit, proceed as follows:

- (1) Remove covers and components as required to gain access to rivet(s) to be replaced. (Refer to chapter 5, section IV.)
- (2) Center punch the rivet head of rivet to be replaced.
- (3) Using a drill smaller than the diameter of the rivet, drill out the center of rivet head to be replaced.
- (4) Increase the size of the drill to rivet size or a size slightly smaller than rivet size, and again drill out rivet head. Rivet head should fall off at this point. If not, position a punch or similar tool against the rivet head and carefully drive it out with a hammer.
- (5) Using a punch and a hammer, punch out the remainder of the rivet to be replaced.
- (6) Obtain and install appropriate size rivet. Using the riveter and appropriate size head, install the replacement rivet.

5-11c. Fasteners. To replace a fastener (2), in the top or bottom access cover, proceed as follows:

- (1) Remove cover to be repaired. (Refer to chapter 5, section IV.)
- (2) Use small needle-nose pliers to remove split-ring washer.
- (3) Remove damaged fastener.
- (4) Insert new fastener through hole in cover and press on split-ring washer.
- (5) Replace cover in accordance with chapter 5, section IV.

Section V. GENERAL SUPPORT TESTING PROCEDURES

5-12. Introduction.

This section contains performance test procedures required to verify proper operation of the DF control/indicator. These procedures should be performed after accomplishing a repair, or prior to system installation.

5-13. Performance Test.

To prepare the DF control-indicator for testing, interconnect the unit and test equipment as described in paragraph 5-5 and figure 5-1, ensure that the power switch, S35, on the test fixture is on, and proceed as follows:

- a. Verify switch/indicators S1 thru S8 are illuminated.
- b. Press and hold PURGE switch/indicator S1 and verify indicator portion is extinguished. Release the switch.
- c. Press and hold INIT switch/indicator S2 and verify indicator portion is extinguished. Release the switch.
- d. Press and hold XMIT TWICE switch/indicator S8 and verify indicator portion is extinguished. Release the switch.
- e. Press and hold SCR switch/indicator S3 and verify indicator portion is extinguished. Release the switch.
- f. Press and hold MSG switch/indicator S4 and verify indicator portion is extinguished. Release the switch.
- g. Press and hold GIST switch/indicator S5 and verify indicator portion is extinguished. Release the switch.
- h. Press and hold EDIT switch/indicator S6 and verify indicator portion is extinguished. Release the switch.
- i. Press and hold DONE switch/indicator S7 and verify indicator portion is extinguished. Release the switch.
- j. End of test. Remove power and disconnect unit from test equipment.

APPENDIX A

REFERENCES

A-1. Technical Manuals

TM 32-5865-007-10	Operation Instructions Special Purpose Countermeasures System, AN/ALQ-151(v)1
TM 32-5865-007-20&P	Maintenance Instructions Organizational, Including Repair Parts and Special Tools List, Special Purpose Countermeasures System AN/ALQ-151(V)1
TM 32-5865-012-10	Operation Instructions, Special Purpose Countermeasures System, AN/ALQ-151(V)2
TM 32-5865-012-20	Maintenance Instructions Organizational, Including Repair Parts and Special Tools List, Special Purpose Countermeasures System, AN/ALQ-151(V)2
TM 32-5865-012-20P	Repair Parts and Special Tools List, AN/ALQ-151(V)2
TM 32-5865-081-24&P	Operator's Organizational, Direct and General Support Maintenance Manual Including Repair Parts and Special Tools List, Test Set OQ-337/ALQ-151
TM 38-230-1	Packaging of Material: Preservation
TM 38-230-2	Packaging of Material: Packing
TM 38-260	Preparation of Industrial Plant Equipment for Storage or Shipment
TM 43-0139	Painting Instructions for Field Use
TM 740-90-1	Administrative Storage of Equipment
TM 750-244-2	Procedures for Destruction of Electronics Material to Prevent Enemy Use (Electronics Command)

TM 32-5865-010-24&P

TM 750-245-4

DS and GS Quality Control:
Inspection Criteria, Inspector's
Inspection Criteria

A-2. Technical Bulletins

TB SIG 222

Solder and Soldering

TB SIG 355-1

Depot Inspection Standards for
Repaired Signal Equipment

TB SIG 355-2

Depot Inspection standard for
Refinishing Repaired Signal
Equipment

TB SIG 355-3

Depot Inspection Standard for
Moisture and Fungus Resistant.
Treatment

TB 43-0118

Field Instructions for Painting and
Preserving Electronics Command
Equipment Including Camouflage
Pattern Painting of Electrical
Equipment Shelters

A-3. Supply Bulletins

SB 11-573

Painting and Preservation Supplies
Available for Field Use for
Electronics Command Equipment

SB 38-100

Preservation, Packaging and Packing
Materials, Supplies and Equipment
Used by the Army

A-4. Common Table of Allowances.

CTA 50-970

Expendable Items

A-5. Pamphlets.

DA PAM 310-1

Index of Administrative
Publications

DA PAM 310-2

Index of Blank Forms

DA PAM 310-4

Index of Technical Publications

DA PAM 738-750

The Army Maintenance Management
System (TAMMS)

A-6. Army Regulations.

AR 310-25	Dictionary of United States Army Terms
AR 310-50	Catalog of Abbreviations and Brevity Codes
AR 700-42	Classification, Reclassification, Maintenance, Insurance, and Reporting of Maintenance Training Aircraft
AR 55-38	Reporting of Transportation Discrepancies in Shipments

A-7. Forms.

DA Form 2028	Recommended Changes to Publications and Blank Forms
DA Form 2404	Equipment Inspection and Maintenance Work Sheets
DA Form 2407	Maintenance Request
DA Form 2408	Equipment Log Assembly (Records)
DA Form 2408-1	Equipment Daily Log
DA Form 2408-5	Equipment Modification Record
SF 361	Discrepancy in Shipment Report
SF 364	Report of Discrepancy
SF 368	Quality Deficiency Report

A-6. Army Regulations.

AR 310-25	Dictionary of United States Army Terms
AR 310-50	Catalog of Abbreviations and Brevity Codes
AR 700-42	Classification, Reclassification, Maintenance, Insurance, and Reporting of Maintenance Training Aircraft
AR 55-38	Reporting of Transportation Discrepancies in Shipments

A-7. Forms.

DA Form 2028	Recommended Changes to Publications and Blank Forms
DA Form 2404	Equipment Inspection and Maintenance Work Sheets
DA Form 2407	Maintenance Request
DA Form 2408	Equipment Log Assembly (Records)
DA Form 2408-1	Equipment Daily Log
DA Form 2408-5	Equipment Modification Record
SF 361	Discrepancy in Shipment Report
SF 364	Report of Discrepancy
SF 368	Quality Deficiency Report

APPENDIX B
MAINTENANCE ALLOCATION CHART

Section I. INTRODUCTION

B-1. General.

a. The maintenance allocation chart identifies the maintenance operations that must be performed. It assigns each of those operations to the lowest level of maintenance authorized to perform the complete task, or any part of the task, in terms of availability of time, tools, test and support equipment, skills and employment of the subsystem.

b. The Maintenance Allocation Chart (MAC) in Section II designates overall responsibility for the performance of maintenance functions for the Direction Finder Control-Indicator C-10144/ALQ-151.

c. Section III lists the special tools and test equipment required for each maintenance function as referenced from Section II.

B-2. Maintenance Functions.

a. Inspect. To determine the serviceability of an item by comparing its physical, mechanical and/or electrical characteristics with established standards through examination.

b. Test. To verify serviceability and detect incipient failure by measuring the mechanical or electrical characteristics of an item and comparing those characteristics with prescribed standards.

c. Service. Operations required periodically to keep an item in proper operating condition; i.e., to clean (decontaminate), preserve, drain, paint or replenish fuel, lubricants, hydraulic fluids, or compressed air supplies.

d. Adjust. To maintain, within prescribed limits, by bringing into proper or exact position, or by setting the operating characteristics to specified parameters.

e. Align. To adjust specified variable elements of an item to bring about optimum or desired performance.

f. Calibrate. To determine and cause corrections to be made or to be adjusted on-instruments or test, measuring and diagnostic equipments used in precision measurement. Consists of comparisons of two instruments, one of which is a certified standard of known accuracy; to detect and adjust any discrepancy in the accuracy of the instrument being compared.

g. Install. The act of emplacing, seating, or fixing into position an item, part, or module (component or assembly) in a manner to allow the proper functioning of an equipment or system.

h. Replace. The act of substituting a serviceable like-type part, subassembly, or module (component or assembly) for an unserviceable counterpart.

i. Repair. The application of maintenance services¹ or other maintenance actions² to restore serviceability to an item by correcting specific damage, fault, malfunction, or failure in a part, subassembly, module (component or assembly), and items, or system.

j. Overhaul. The maintenance effort (services/actions) necessary to restore an item to a completely serviceable/operational condition as prescribed by maintenance standards (i.e., DMWR) in appropriate technical publication. Overhaul is normally the highest degree of maintenance performed by the Army. Overhaul does not normally return an item to like-new condition.

k. Rebuild. Consists of those services/actions necessary for the restoration of unserviceable equipment to a like-new condition in accordance with original manufacturing standards. Rebuild is the highest degree of materiel maintenance applied to Army equipment. The rebuild operation includes the act of returning to zero those age measurements (hours/miles, etc.) considered in classifying Army equipments/components.

B-3. Column Entries Used in the MAC.

a. Column 1, Group Number. Column 1 lists group numbers, the purpose of which is to identify components, assemblies, subassemblies, and modules with the next higher assembly.

b. Column 2, Component/Assembly. Column 2 contains the names of components, assemblies, subassemblies, and modules for which maintenance is authorized.

c. Column 3, Maintenance Functions. Column 3 lists the functions to be performed on the item listed in column 2. (For detailed explanation of these functions, see para. B-2).

d. Column 4, Maintenance Category.

(1) Column 4 specifies, by the listing of a "work time" figure in the appropriate sub-column(s), the lowest level of

¹services - inspect, test, service, adjust, align, calibrate, or replace.

²Action - welding, grinding, riveting, straightening, facing, remachining, or resurfacing.

maintenance authorized to perform the function listed in column 3. This figure represents the active time required to perform the maintenance function, at the indicated level of maintenance.

(2) If the number or complexity of the tasks within the listed maintenance function vary at different maintenance, appropriate "work time" figures will be shown for each level. The number of man-hours specified by the "work time" figure represents the average time required to restore an item (assembly, subassembly, component, module, end item, or system) to a serviceable condition under typical field operating conditions. This time includes preparation time, troubleshooting time, and quality assurance/quality control time in addition to the time required to perform the specific tasks identified for the maintenance functions authorized in the maintenance allocation chart. The symbol designations for the-various maintenance levels are as follows:

- C - Operator or crew.
- O - Organizational maintenance.
- F - Direct support maintenance.
- H - General support maintenance.
- D - Depot maintenance.

e. Column 5, Tools and Equipment. Column 5 specifies, by code, those common tool sets (not individual tools) and special tools, test, and support equipment required to perform the designated function.

f. Column 6, Remarks. Column 6 contains a letter code in alphabetical order which is keyed to the remarks contained in Section IV; If no remarks were necessary, the column will remain blank and Section IV will be deleted.

B-4. Column Entries Used in Tool and Test Equipment Requirements (Section III).

a. Column 1, Tool or Test Equipment Reference Code. The tool and test equipment reference code correlates with a maintenance function on the identified end item or component.

b. Column 2, Maintenance Category. The lowest level of maintenance authorized to use the tool or test equipment.

c. Column 3, Nomenclature. Name or identification of the tool or test equipment.

d. Column 4, National/NATO Stock Number. The National or NATO stock number of tool or test equipment.

e. Column 5, Tool Number. The manufacturer's part number.

B-5. Explanation of Columns in Section IV.

a. Reference Code. The code scheme recorded in Column 1, Section III.

b. Remarks. This column lists information pertinent to the maintenance function being performed as indicated on the MAC, Section II. If no remarks are applicable, column 6 of Section II remains blank and Section IV is deleted.

**Section II. MAINTENANCE ALLOCATION CHART
FOR
DIRECTION FINDER CONTROL-INDICATOR
C-10144/ALQ-151**

(1) GROUP NUMBER	(2) COMPONENT/ASSEMBLY	(3) MAINTENANCE FUNCTION	(4) MAINTENANCE CATEGORY					(5) TOOLS AND EQUIPMENT	(6) REMARKS
			C	O	F	H	D		
28	CONTROL-INDICATOR, DIRECTION FINDER	Inspect				0.2		6	
		Test				0.1		1,3,4,6	
		Service				0.2		6	
		Repair				0.3		1,3,4,6	
2801	PANEL, FRONT	Inspect				0.1		6	
		Replace				0.3		2,3,6	
		Repair				0.2		2,6	
2802	PANEL, SIDE	Inspect				0.1		6	
		Replace				0.1		6	
		Repair				0.3		5,6,7	
2803	PANEL, SIDE	Inspect				0.1		6	
		Replace				0.1		6	
		Repair				0.3		6,7	

SECTION III. TOOL AND TEST EQUIPMENT REQUIREMENTS FOR
DIRECTION FINDER CONTROL-INDICATOR C-10144/ALQ-151

TOOL OR TEST EQUIPMENT REF CODE	MAINTENANCE CATEGORY	NOMENCLATURE	NATIONAL/NATO STOCK NUMBER	TOOL NUMBER
1	H	MULTIMETER, DIGITAL	6625-01-139-2512	AN/PSM-45
2	H	HAND INSTALLATION TOOL	TBD	H7503-X
3	H	MAINT KIT ELECTRONIC	6625-01-068-1665	MK-1961/G
4	H	TEST SET GROUP	5865-01-190-5562	OQ-337/ALQ-151
5	H	TOOL KIT, ELEC EQUIP	5180-00-605-0079	TK-100/G
6	H	TOOL KIT, ELEC EQUIP	5180-00-610-8177	TK-105/G
7	H	RIVETER KIT	6665-01-022-4165	HP-200

Section II. MAINTENANCE ALLOCATION CHART
FOR
DIRECTION FINDER CONTROL-INDICATOR
C-10144/ALQ-151

(1) GROUP NUMBER	(2) COMPONENT/ASSEMBLY	(3) MAINTENANCE FUNCTION	(4) MAINTENANCE CATEGORY					(5) TOOLS AND EQUIPMENT	(6) REMARKS
			C	O	F	H	D		
28	CONTROL-INDICATOR, DIRECTION FINDER	Inspect				0.2		6	
		Test				0.1		1,3,4,6	
		Service				0.2		6	
		Repair				0.3		1,3,4,6	
2801	PANEL, FRONT	Inspect				0.1		6	
		Replace				0.3		2,3,6	
		Repair				0.2		2,6	
2802	PANEL, SIDE	Inspect				0.1		6	
		Replace				0.1		6	
		Repair				0.3		5,6,7	
2803	PANEL, SIDE	Inspect				0.1		6	
		Replace				0.1		6	
		Repair				0.3		6,7	

SECTION III. TOOL AND TEST EQUIPMENT REQUIREMENTS FOR
DIRECTION FINDER CONTROL-INDICATOR C-10144/ALQ-151

TOOL OR TEST EQUIPMENT REF CODE	MAINTENANCE CATEGORY	NOMENCLATURE	NATIONAL/NATO STOCK NUMBER	TOOL NUMBER
1	H	MULTIMETER, DIGITAL	6625-01-139-2512	AN/PSM-45
2	H	HAND INSTALLATION TOOL	TBD	H7503-X
3	H	MAINT KIT ELECTRONIC	6625-01-068-1665	MK-1961/G
4	H	TEST SET GROUP	5865-01-190-5562	OQ-337/ALQ-151
5	H	TOOL KIT, ELEC EQUIP	5180-00-605-0079	TK-100/G
6	H	TOOL KIT, ELEC EQUIP	5180-00-610-8177	TK-105/G
7	H	RIVETER KIT	6665-01-022-4165	HP-200

APPENDIX C

REPAIR PARTS AND SPECIAL TOOLS LIST

Section I. INTRODUCTION

C-1 . Scope

This manual lists spares and repair parts; special tools; special test, measurement, and diagnostic equipment (TMDE), and other special support equipment required for performance of organizational, direct support, and general support maintenance of the C-10144/ALQ-151. It authorizes the requisitioning and issue of spares and repair parts as indicated by the source and maintenance codes.

C-2 . General

This Repair Parts and Special Tools List is divided into the following sections:

a. Section II. Repair Parts List. A list of spares and repair parts authorized for use in the Performance of maintenance. The list

b. Section III. Special Tools List. A list of special tools, special TMDE, and other special support equipment authorized for the performance of maintenance.

Section IV. National Stock Number and Part Number Index. A list, in National item identification number (NIIN) sequence, of all National stock numbers (NSNS) appearing in the listings, followed by a list, in alphameric sequence, of all part numbers appearing in the listings. National stock numbers and part numbers are cross-referenced to each illustration figure and item number appearance.

C-3 . Explanation of Columns

a. Illustration. This column is divided as follows:

(1) Figure number. Indicates the figure number of the illustration on which the item is shown.

(2) Item number. The number used to identify item called out in the illustration.

b. Source, Maintenance, and Recoverability (SMR) Codes.

(1) Source code. Source codes indicate the manner of acquiring support items for maintenance, repair, or overhaul of end items. Source codes are entered in the first and second positions of the Uniform SMR Code format as follows:

<u>Code</u>	<u>Definition</u>
PA	- Item procured and stocked for anticipated or known usage.
XB	- Item is not procured or stocked. If not available through salvage, requisition.

NOTE

Cannibalization or salvage may be used as a source of supply for any items coded above except those coded XA and aircraft support items as restricted by AR 700-42.

(2) Maintenance code. Maintenance codes are assigned to indicate the levels of maintenance authorized to USE and REPAIR support items. The maintenance codes are entered in the third and fourth positions of the Uniform SMR Code format as follows:

(a) The maintenance code entered in the third position will indicate the lowest maintenance level authorized to remove, replace, and use the support item. The maintenance code entered in the third position will indicate one of the following levels of maintenance:

<u>Code</u>	<u>Application/Explanation</u>
F	- Support item is removed, replaced, used at the direct support level.

(b) The maintenance code entered in the fourth position indicates whether the item is to be repaired and identifies the lowest maintenance level with the capability to perform complete repair (i.e., all authorized maintenance functions). This position will contain one of the following maintenance codes.

<u>Code</u>	<u>Application/Explanation</u>
F	- . The lowest maintenance level capable of complete repair of the support item is the direct support level.
Z	- Nonreparable. No repair is authorized.

(3) Recoverability code. Recoverability codes are assigned to support items to indicate the disposition action on unserviceable items. The recoverability code is entered in the fifth position of the Uniform SMR Code format as follows:

Recoverability Codes

Definition

- Z - Nonreparable item. When unserviceable, condemn and dispose at the level indicated in position 3.
- F - Reparable item. When uneconomically reparable, condemn and dispose at the direct support level.

c. National Stock Number. Indicates the National stock number assigned to the item and will be used for requisitioning.

d. Part Number. Indicates the primary number used by the manufacturer (individual, company, firm, corporation, or Government activity), which controls the design and characteristics of the item by means of its engineering, drawings, specifications, standards, and inspection requirements to identify an item or range of items.

NOTE

When a stock numbered item is requisitioned, the repair part received may have a different part number than the part being replaced.

Federal Supply Code for Manufacturer (FSCM). The FSCM is a 5-digit numeric code listed in SB 708-42 which is used to identify the manufacturer, distributor, or Government agency, etc.

Indicates the Federal item name and, if required, a minimum description to identify the item .

Unit of Measure (U/M). Indicates the standard of the basic quantity of the listed item as used in performing the actual maintenance function. This measure is, expressed by a two-character alphabetical abbreviation (e.g., ea, in, pr, etc.). When the unit of measure differs from the unit of issue, the lowest unit of issue that will satisfy the required units of measure will be requisitioned.

h. Quantity Incorporated in Unit. Indicates the quantity of the item used in the breakout shown on the illustration figure, which is prepared for a functional group, subfunctional group, or an assembly.

C-4. Special Information.

a. National stock numbers (NSNS) that are missing from P source coded items have been applied for and will be added to this TM by future change/revision when they are entered in the Army Master Data File (AMDF). Until the NSNS are established and published, submit exception requisitions to: Commander, U.S. Army Communications and Electronics Materiel Readiness Command: Vint Hill Farms Station, Warrenton, Virginia 22186 for the part required to support your equipment.

b. (Applicable to revisions or changes only.) Action change codes indicated in the left-hand margin of the listing page denote the following:

- N - Indicates an added item
- C - Indicates a change in data
- R - Indicates a change in NSN only

C-5. How to Locate Repair Parts.

a. When National stock number or part number is not known.

(1) Using the table of contents, determine the functional group within which the item belongs. This is necessary since illustrations are prepared for functional groups and listings are divided into the same-groups.

(2) Find the illustration covering the functional group to which the item belongs.

(3) Identify the item on the illustration and note the illustration figure and item number of the item

(4) Using the Repair Parts Listing, find the figure and item number noted on the illustration.

b. When National stock number or part number is known.

(1) Using the Index of National Stock Numbers and Part Numbers, find the pertinent National stock number or part number. This index is in NIIN sequence followed by a list of part numbers in alphameric sequence, cross-referenced to the illustration figure number and item number.

(2) After finding the figure and item number, locate the figure and item number in the repair parts list.

C-6. Abbreviations.

Not applicable.

Section II. REPAIR PARTS LIST

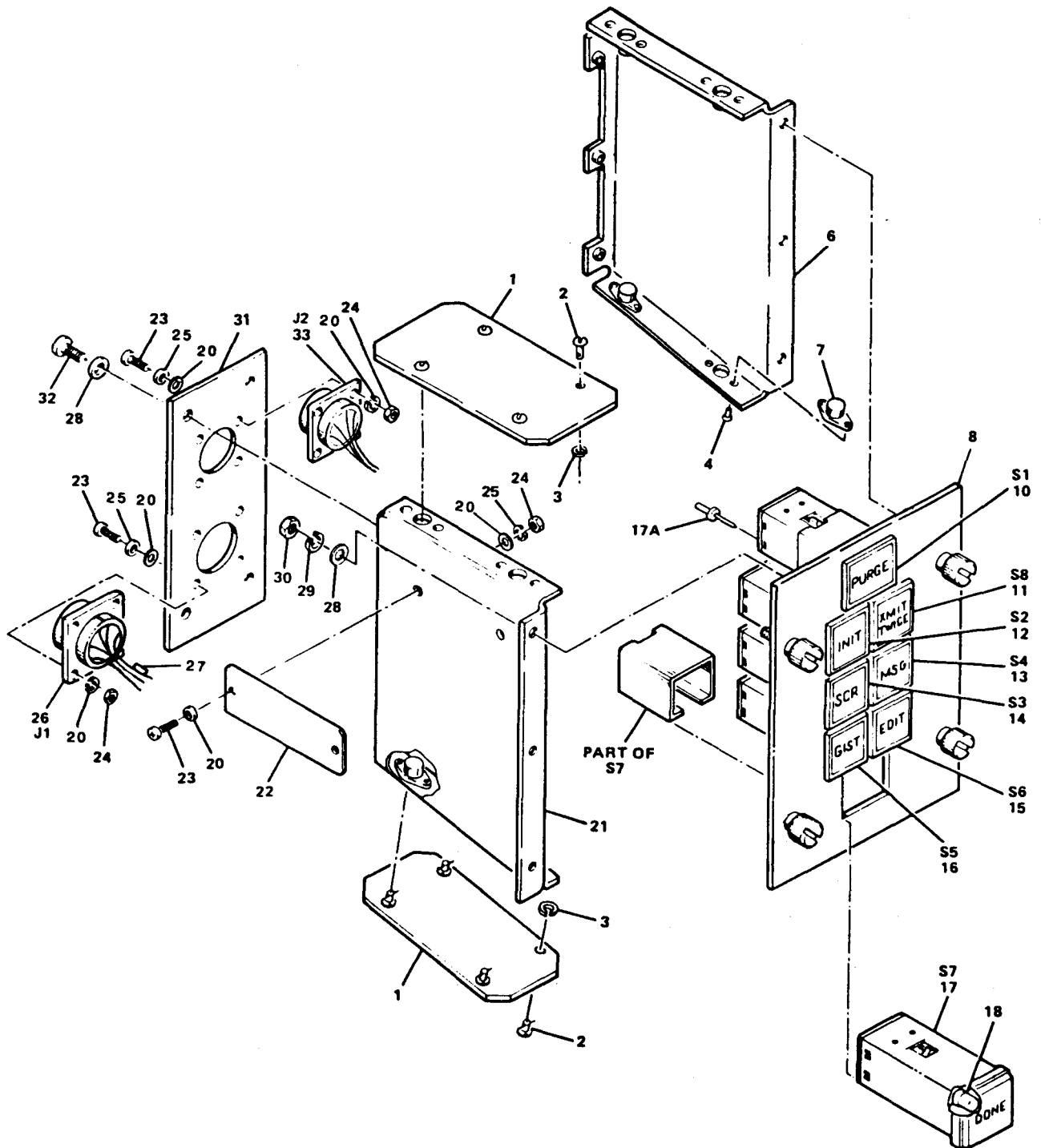

Figure C-1. Direction Finder Control Indicator C-10144/ALQ-151

SECTION II. REPAIR PARTS LIST

ILLUS RATION		(2)	(3)	(4)	(5)	(6)	(7)	(8)
FIG NO	ITEM NO	SMR OD	NATIONAL STOCK NUMBER	PART NUMBER	FSCM	DESCRIPTION USABLE ON CODE	U/M	QTY INC IN UNIT
						GP 00 - CONTIND C-10144/ALQ-151 1951-1-4028-1 (15942)		
C-1	1	XDHHH		1951-1-3084-1	15942	COVER, ACCESS	EA	2
C-1	2	XDHZZ	5325-00-616-5176	5S5-6	71286	STUD, TURNLOCK, FSTNR	EA	8
C-1	3	XDHZZ	5310-00-793-4947	5S3-1	71286	WASHER, SPLIT	EA	8
C-1	4	XDHZZ	5320-00-117-6938	MS20426AD3-4	96906	RIVET, SOLID	EA	16
C-1	5					NOT USED		
C-1	6	XDHHH		1951-1-4552-4	15942	PANEL, SIDE	EA	1
C-1	7	XDHZZ	5325-00-758-0113	5R2-3	71286	RCPT, TURNLOCK	EA	8
C-1	8	XDHZZ		1951-1-4241-1	15942	PANEL, FRONT	EA	1
C-1	9					NOT USED		
C-1	10	PAHZZ	5930-01-068-3640	10648EL3-16	08719	SWITCH, PUSH	EA	1
C-1	11	PAHZZ	5930-01-068-9470	10648EL3-12	08719	SWITCH, PUSH	EA	1
C-1	12	PAHZZ	5930-01-233-3277	10648EL3-6	08719	SWITCH, PUSH	EA	1
C-1	13	PAHZZ	5930-01-068-3641	10648EL3-8	08719	SWITCH, PUSH	EA	1
C-1	14	PAHZZ	5930-01-068-2708	10648EL3-10	08719	SWITCH, PUSH	EA	1
C-1	15	PAHZZ	5930-01-068-2709	10648EL3-7	08719	SWITCH, PUSH	EA	1
C-1	16	PAHZZ	5930-01-068-9469	10648EL3-9	08719	SWITCH, PUSH	EA	1
C-1	17	PAHZZ	5930-01-068-2710	10648EL3-15	08719	SWITCH, PUSH	EA	1
C-1	17A	XDHZZ		M39029/1-16-20	81349	CONTACT, ELEC	EA	43
C-1	18	PAHZZ	6240-00-763-7744	MS25237-387	96906	LAMP, INCAND	EA	16
C-1	19					NOT USED		
C-1	20	XDHZZ	5310-00-595-6211	MS15795-803	96906	WASHER, FLAT	EA	18
C-1	21	XDHHH		1951-1-4552-3	15942	PANEL, SIDE	EA	1
C-1	22	XDHZZ		C5074128-4	57958	PLATE, IDENT	EA	1
C-1	23	XDHZZ	5305-00-054-5649	MS51957-15		SCREW, MACHINE	EA	10
C-1	24	XDHZZ	5310-00-208-3786	NAS671C4	80205	NUT, PLAIN, HEX	EA	10
C-1	25	XDHZZ	5310-00-933-8118	MS35338-135	96906	WASHER, LOCK	EA	10
C-1	26	XDHZZ	5935-01-023-4847	MS27508E16F35S	96906	CONN, RCPT, ELEC	EA	1
C-1	27	XDHZZ		D-144-25		SPLICE, CONDUCTOR	EA	5
C-1	28	XDHZZ	5310-00-722-5998	MS15795-805	96906	WASHER, LOCK	EA	12
C-1	29	XDHZZ	5310-00-929-6395	MS35338-136	96906	WASHER, LOCK	EA	6
C-1	30	XDHZZ	5310-00-616-8660	NAS671C6	80205	NUT, PLAIN, HEX	EA	6
C-1	31	XDHZZ		1951-1-4242-1	15942	PANEL, REAR	EA	1
C-1	32	XDHZZ	5305-00-054-6652	MS51957-28	96906	SCREW, MACHINE	EA	6
C-1	33	XDHZZ	5935-01-056-3259	MS27508E14F18S	96906	CONN, RCPT, ELEC	EA	1

Section III. SPECIAL TOOLS LIST

Not Applicable

Section IV. NATIONAL STOCK NUMBER AND PART NUMBER INDEX

NATL STOCK NUM	FIGURE	ITEM	PART NUMBER	FSCM	FIGURE	ITEM
	C-1	6	C5074128-4	57958	C-1	22
	C-1	8	D144-25	06090	C-1	27
	C-1	12	MS15795-803	96906	C-1	20
	C-1	17A	MS15795-805	96906	C-1	28
	C-1	21	MS20426AD3-4	96906	C-1	4
	C-1	22	MS25237-387	96906	C-1	18
	C-1	27	MS27508E14F18S	96906	C-1	33
	C-1	31	MS27508E16F35S	96906	C-1	26
5305-00-054-5649	C-1	23	MS35338-135	96906	C-1	25
5305-00-054-6652	C-1	32	MS35338-136	96906	C-1	29
5310-00-208-3786	C-1	24	MS51957-15	96906	C-1	23
5310-00-595-6211	C-1	20	MS51957-28	96906	C-1	32
5310-00-616-8660	C-1	30	M39029/1-16-20	81349	C-1	17A
5310-00-722-5998	C-1	28	NAS671C4	80205	C-1	24
5310-00-793-4947	C-1	3	NAS671C6	80205	C-1	30
5310-00-929-6395	C-1	29	10648EL3-10	08719	C-1	14
5310-00-933-8118	C-1	25	10648EL3-12	08719	C-1	11
5320-00-117-6938	C-1	4	10648EL3-15	08719	C-1	17
5325-00-616-5176	C-1	2	10648EL3-16	08719	C-1	10
5325-00-758-0113	C-1	7	10648EL3-6	08719	C-1	12
5930-01-068-2708	C-1	14	10648EL3-7	08719	C-1	15
5930-01-068-2709	C-1	15	10648EL3-8	08719	C-1	13
5930-01-068-2710	C-1	17	10648EL3-9	08719	C-1	16
5930-01-068-3640	C-1	10	1951-1-3084-1	15942	C-1	1
5930-01-068-3641	C-1	13	1951-1-4241-1	15942	C-1	8
5930-01-068-9469	C-1	16	1951-1-4242-1	15942	C-1	31
5930-01-068-9470	C-1	11	1951-1-4552-3	15942	C-1	21
5935-01-023-4847	C-1	26	1951-1-4552-4	15942	C-1	6
5935-01-056-3259	C-1	33	5R2-3	71286	C-1	7
6240-00-763-7744	C-1	18	5S3-1	71286	C-1	3
			5S5-6	71286	C-1	2

APPENDIX D
EXPENDABLE SUPPLIES AND MATERIALS LIST

Section I. INTRODUCTION

D-1. SCOPE

This appendix lists expendable supplies and materials you will need to operate and maintain the DF control/indicator. These items are authorized to you by CTA 50-970, Expendable Items (Except Medical, Class V, Repair Parts, and Heraldic Items).

D-2. EXPLANATION OF COLUMNS

a. Column(1)- Item number. This number is assigned to the entry in the listing and is referenced in the narrative instructions to identify the material (e.g., "Use cleaning compound, item 5, App. D").

b. Column(2)- Level. This column identifies the lowest level of maintenance that requires the listed item.

(enter as applicable)

- C - Operator/Crew
- O - Organizational Maintenance
- F - Direct Support Maintenance
- H - General Support Maintenance

c. Column(3)- National Stock Number. This is the National stock number assigned to the item; use it to request or requisition the item.

d. Column(4)- Description. Indicates the Federal item name and, if required, a description to identify the item. The last line for each item indicates the Federal Supply Code for Manufacturer (FSCM) in parentheses followed by the part number.

e. Column(5)- Unit of Measure (U/M). Indicates the measure used in performing the actual maintenance function. This measure is expressed by a two-character alphabetical abbreviation (e.g., ea, in, pr). If the unit of measure differs from the unit of issue, requisition the lowest unit of issue that will satisfy your requirements.

Section II. EXPENDABLE SUPPLIES AND MATERIALS LIST

(1) ITEM NO.	(2) LEVEL	(3) <u>NSN</u>	(4) <u>DESCRIPTION</u>	(5) <u>U/M</u>
1	H	8029-00-246-8806	Brush, soft	ea
2	H	8305-00-267-3015	Cloth, lint-free	ro
3	H	8415-00-200-7013	Gloves, rubber heavy duty	pr
4	H	4020-00-656-1125	Tape, lacing, size 4, black (MIL-T-713)	ro
5	H	6850-00-984-5853	Trichlorotrifluoroethane, (MIL-C-18718)	gl
6	H	6145-01-845-5205	Wire, electrical, 24 AWG, white	in

INDEX

	Paragraph figure/table	Page
A		
B		
C		
Calibration.	1-5	1-1
D		
DF Control-Indicator C-10144/ALQ-151.	1-8, F1-1, F5-2, F5-3	1-2, 1-3, 5-8, 5-11
Functional Description.	3-2	3-1
Physical and Electrical Characteristics	T1-1	1-2
F		
Fasteners.	5-11c	5-12
Functional Description	3-2	3-1
Functioning of Equipment.		3-1
M		
Maintenance, General Support.		5-1
Performance Test.	5-13	5-13
Removal and Replacement Procedures		
Connector J1 and J2.	5-10c	5-7
Front Panel.	5-10d	5-9
Identification Plate	5-10f	5-10
Left and Right Side Panel.	5-10e	5-9
Rear Panel.	5-10b	5-7
Switch/Indicator Assembly.	F5-3	5-11
Top and Bottom Cover	5-10a	5-7
Repairs.	5-11	5-10
Fasteners.	5-11c	5-12
Riveting.	5-11b	5-12
Switch/Indicator Removal and Replacement	5-11a	5-10
Special Test Equipment	5-3	5-1
Test Setup Procedures	5-5, F5-1	5-2, 5-3

INDEX - Continued

	Paragraph figure/table	Page
Tools and Test Equipment.	5-2, 5-3, T5-1	5-1, 5-1, 5-1
Troubleshooting Procedures.	5-6, T5-2	5-2, 5-4
P		
Performance Test.	5-13	5-13
Physical and Electrical Characteristics	T1-1	1-2
R		
Removal and Replacement	5-10	5-7
Repair.	5-11	5-10
Riveting.	5-11b	5-2
T		
Test Procedures.	T5-2, 5-13	5-5, 5-10
Test Setup Procedures	5-5, F5-1	5-2, 5-3
Tools and Test Equipment.	5-2, 5-3, T5-1,	5-1, 5-1, 5-1
Troubleshooting	T5-2	5-5

By Order of the Secretary of the Army:

CARL E. VUONO
General. United States Army
Chief of Staff

Official:

WILLIAM J. MEEHAN 11
Brigadier General. United States Army
The Adjutant General



SOMETHING WRONG WITH THIS MANUAL?

THEN... JOT DOWN THE DOPE ABOUT IT ON THIS FORM, TEAR IT OUT, FOLD IT AND DROP IT IN THE MAIL!

FROM: (YOUR UNIT'S COMPLETE ADDRESS)

Commander
Stateside Army Depot
ATTN: AMSTA-US
Stateside, N.J. 07703

DATE 10 July 1975

PUBLICATION NUMBER

TM 32-5865-010-24&P

PUBLICATION DATE

14 December 1984

PUBLICATION TITLE

Direction Fire Control-Indicator C-10144/ALO-151 (NSN 5865-01-070-8961)

BE EXACT... PIN-POINT WHERE IT IS

IN THIS SPACE TELL WHAT IS WRONG AND WHAT SHOULD BE DONE ABOUT IT:

PAGE NO.	PARA-GRAPH	FIGURE NO.	TABLE NO.
2-25	2-28		
3-10	3-3		3-1
5-6	5-8		
		F03	

Recommend that the installation antenna alignment procedure be changed through to specify a 2° IFF antenna lag rather than 1°.

REASON: Experience has shown that with only a 1° lag, the antenna servo system is too sensitive to wind gusting in excess of 7 knots, and has a tendency to rapidly accelerate and decelerate as it hunts, causing strain to the drive train. Hunting is minimized by adjusting the lag to 2° without degradation of operation.

Item 5, Function column. Change "2 db" to "3db."

REASON: The adjustment procedure for the TRANS POWER FAULT indicator calls for a 3 db (500 watts) adjustment to light the TRANS POWER FAULT indicator.

Add new step f.1 to read, "Replace cover plate removed in step e.1, above."

REASON: To replace the cover plate.

Zone C 3. On J1-2, change "+24 VDC to "+5 VDC."

REASON: This is the output line of the 5 VDC power supply. + 24 VDC is the input voltage.

TEAR ALONG DOTTED LINE

TYPED NAME, GRADE OR TITLE, AND TELEPHONE NUMBER

SSG I. M. DeSpirito 999-1776

SIGN HERE:

SSG I. M. DeSpirito

RECOMMENDED CHANGES TO EQUIPMENT TECHNICAL PUBLICATIONS

SOMETHING WRONG WITH THIS PUBLICATION?



THEN... JOT DOWN THE DOPE ABOUT IT ON THIS FORM, CAREFULLY TEAR IT OUT, FOLD IT AND DROP IT IN THE MAIL!

FROM: (PRINT YOUR UNIT'S COMPLETE ADDRESS)

DATE SENT

PUBLICATION NUMBER

TM 32-5865-010-24&P

PUBLICATION DATE

3 Feb 86

PUBLICATION TITLE Direction Finder Control C-10144/ALQ-151

BE EXACT... PIN-POINT WHERE IT IS

PAGE NO.	PARA-GRAPH	FIGURE NO.	TABLE NO.
----------	------------	------------	-----------

IN THIS SPACE TELL WHAT IS WRONG AND WHAT SHOULD BE DONE ABOUT IT:

TEAR ALONG PERFORATED LINE

PRINTED NAME, GRADE OR TITLE, AND TELEPHONE NUMBER

SIGN HERE:

**FILL IN YOUR
UNIT'S ADDRESS**

FOLD BACK

DEPARTMENT OF THE ARMY

**OFFICIAL BUSINESS
PENALTY FOR PRIVATE USE \$300**

**POSTAGE AND FEES PAID
DEPARTMENT OF THE ARMY
DOD 314**



Commander
US Army Electronics Materiel Readiness Activity
ATTN: SELEM-ME-E
Vint Hill Farms Station
Warrenton, VA 22186

RECOMMENDED CHANGES TO EQUIPMENT TECHNICAL PUBLICATIONS

SOMETHING WRONG WITH THIS PUBLICATION?



THEN... JOT DOWN THE DOPE ABOUT IT ON THIS FORM, CAREFULLY TEAR IT OUT, FOLD IT AND DROP IT IN THE MAIL!

FROM: (PRINT YOUR UNIT'S COMPLETE ADDRESS)

DATE SENT

PUBLICATION NUMBER

TM 32-5865-010-24&P

PUBLICATION DATE

3 Feb 86

PUBLICATION TITLE Direction Finder
Control C-10144/ALQ-151

BE EXACT... PIN-POINT WHERE IT IS

PAGE NO.

PARA-GRAPH

FIGURE NO.

TABLE NO.

IN THIS SPACE TELL WHAT IS WRONG AND WHAT SHOULD BE DONE ABOUT IT:

TEAR ALONG PERFORATED LINE

PRINTED NAME, GRADE OR TITLE, AND TELEPHONE NUMBER

SIGN HERE:

**FILL IN YOUR
UNIT'S ADDRESS**



FOLD BACK

DEPARTMENT OF THE ARMY

**OFFICIAL BUSINESS
PENALTY FOR PRIVATE USE \$300**

**POSTAGE AND FEES PAID
DEPARTMENT OF THE ARMY
DOD 314**



Commander
US Army Electronics Materiel Readiness Activity
ATTN: SELEM-ME-E
Vint Hill Farms Station
Warrenton, VA 22186

